



# Ottawa 4x2 Off Road Standard Specifications

## 4X2 YARD TRACTOR

### STANDARD FEATURES

- Cummins Tier 3 QSB6.7-160 HP @2200 RPM, 540-lb/ft torque @1500 RPM  
Electronic-CAC with primary fuel filter
- Allison 3000RDS Transmission (3 speed)
- Front Axle: Meritor FF-961, 12,000 lb
- Rear Axle: Meritor RS-23-186, 7.83:1 ratio, solid mount to frame
- 110" Wheelbase with "L" frame reinforcement
- Fifth wheel: Holland FW-3500, 70,000 lb plate rating
- Fifth wheel lift cylinders: 5" diameter 60,000 lb rating
- Tires 11R22.5 Steel belted radials 14PR
- Wheels 22.5" X 8.25" 285 mm hub piloted, 10 hole steel disc
- Vertical exhaust system with heat shield
- Air cleaner, frontal inlet
- Back-up light, stop and turn signals
- Step - battery box 16" wide
- Cab side vent (riveted)
- Drive shaft Spicer 1710 series
- Approximate Vehicle Weight 14,500 lb
- GCWR 96,000 Lbs
- Maximum Ground Speed 25 MPH

### TRAILER EQUIPMENT

- Two (2) color coded, coiled air lines with glad hand receivers, 7 wire female receptacle at rear of cab

### STEERING

- Gearbox type integral power steering with mechanical back up
- Constant running PTO/pump with priority steering circuit

### CAB FEATURES

- Cab air ride, 3-point mount suspension
- Cab with raised roof: 50" X 65" X 68" welded steel and driver's side door which has a full length piano hinge and an aluminum sliding rear door
- Cab insulation, for thermal protection and noise abatement
- Cab tilt: Electric 45° with 90° tilt capability
- Platform, rear of cab
- Air Ride Seat with isolator
- Seat belt with 2-point mount
- Tinted glass all windows
- 40,000 BTU fresh air heater/defroster
- West coast 16" X 7" mirrors

#### Cab gauges:

Volt meter, oil pressure, water temperature, fuel level, air pressure, speedometer and 5-digit hour-meter

#### Cab controls:

Accelerator, tractor/trailer brakes, gear selector, fifth wheel elevation, steering wheel 18" soft touch, headlights, electric horn, heater defroster and electric windshield wiper control, directional turn signals, rear flood light upper right hand side, 5th wheel unlatch

### WARNING DEVICES

- Low air pressure light and alarm
- Transmission high oil temperature warning
- Headlight hi-beam indicator
- Electric backup alarm

# Ottawa 4x2 Off Road

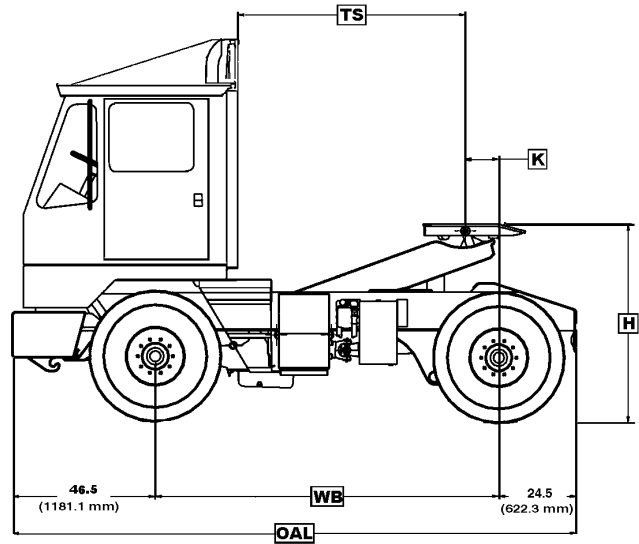
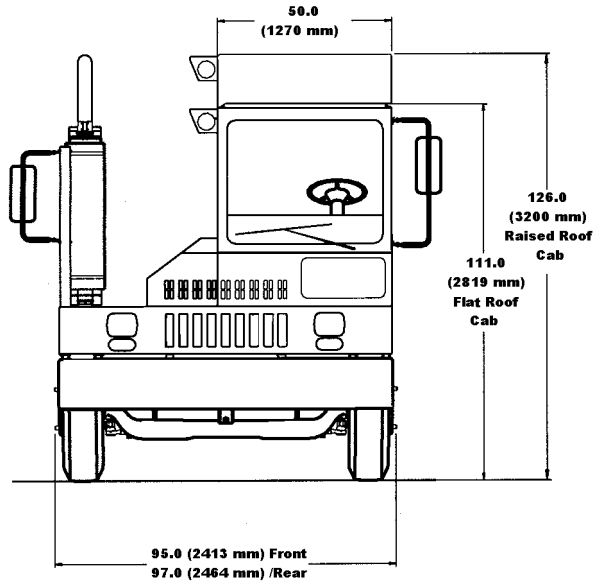

		BOOM POSITION STANDARD LIFT	
WB	DIM	UP	DOWN
110" (2794 mm)	TS	73.4 (1863 mm)	77.5 (1958 mm)
	K	10.2 (259 mm)	6.1 (154 mm)
	H	63 (1600.2 mm)	46 (1168.4 mm)
	OAL	181 (4597.4 mm)	

## HYDRAULIC SYSTEM

- 16 gallon tank with sight glass
- 10 GPM pump
- 5" hydraulic lift cylinders
- Hydraulic system fittings with "O" Ring
- 5th Wheel Boom lift 17"

## BRAKES

- Front: "S" Cam type 16.5" X 5" air actuated
- Rear "S" Cam type 16.5" x 7" air actuated
- Manual slack adjusters front and rear

## FRAME FEATURES

- Welded 50,000 psi steel with 12" x 3 3/8" X 3/8" formed channel 43.25" wide frame with "L" frame reinforcement (1,835,000 in/lb RBM)
- 55° tapered deck curbside with reinforced removable bumper
- 50-gallon frame mounted round fuel tank, curbside
- Integral front and rear tow eyes

## PNEUMATIC SYSTEM

- 15.2 CFM Wabco compressor with 2-tank air reservoir system total capacity 3582 cu. in.
- Color-coded air lines

## ELECTRICAL SYSTEM

- 12 Volt neg. ground with circuit breakers, 130-amp minimum charge alternator, color coded wiring in separate removable harness, 12-volt starter with positive engagement, two (2) 12-volt low maintenance batteries, cab dome light

## PAINT FINISH

- Cab: white DuPont Imron 5000
- Chassis and components powder coated primer, top coated with polyurethane, paint black
- Wheels: Paint "E" coat white
- Rubberized undercoating under cab and deck

